



БК

AXIAL FANS

Fan Components and Material Properties

Body and fan are made of electrostatic powder coated sheet steel. The motor and fan impeller are connected to the main body by steel carriers. Easily mounted on windows and wall. Provides strong airflow thanks to ideal blade angles.

Benefits

Provides strong airflow thanks to ideal blade angles. Covered structure with unwanted air, dust, rain, etc. prevents entry. It has a compact design.

Speed Control

Optional control devices can be provided.

* Speed control can be done with linear voltage regulator. (see BSC accessory)

Usage Areas

It is used in the kitchen, bathroom, office and workplaces where smelly, smoke-like air is required to be discharged.

Technical Drawing and Tables

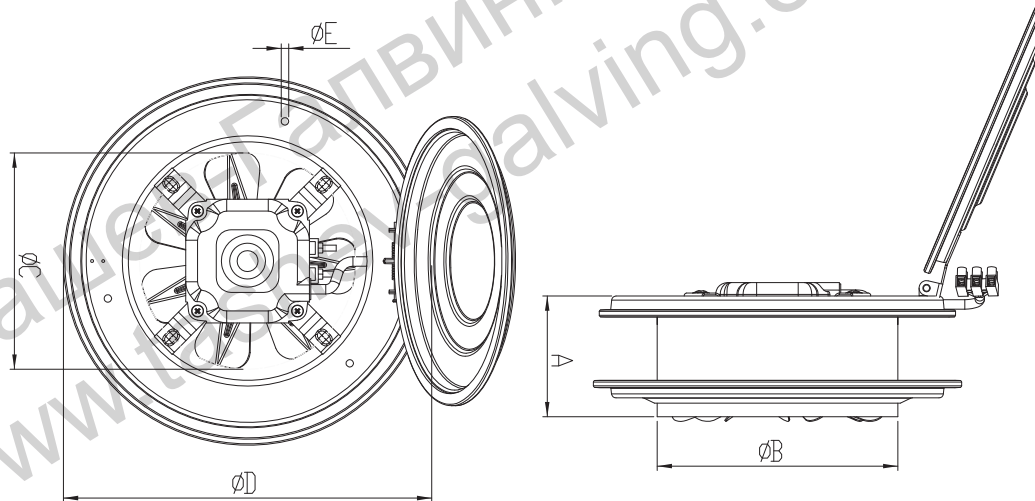

TYPE	A (± 2)	B	C	D	E
BK 160	100	162	148	236	5
BK 200	100	202	178	282	5
BK 250	100	248	234	332	5
BK 300	100	298	284	380	5

Dimensions are in (mm)

TYPE	VOLTAGE	FREQUENCY	POWER	CURRENT	SPEED	AIR FLOW	SOUND PRESSURE	INSULATION CLASS	PROTECTION CLASS	WEIGHT	PIECES IN BOX
	V	Hz	W	(A)	r.p.m	m ³ /h	dB(A)	Ins.cl.	IP	kg	AD
BK 160	230	50/60	25	0,15	1450	450	40	B	44	1,8	8
BK 200	230	50/60	28	0,15	1250	780	42	B	44	2,1	8
BK 250	230	50/60	48	0,33	1450	890	46	B	44	3,1	8
BK 300	230	50/60	50	0,33	1350	1150	50	B	44	2,8	8

The sound level is measured at a distance of 3 m in open field condition.